

DESCRIPTION

Series 479 Panic Bolt Protectors are designed to offer protection to the hardware while providing a 10" pushing surface for wheelchair users.

TECHNICAL DATA

Material: 18 gauge, type 304 stainless steel with a #4 satin finish.

MODELS

Model 479: no cap, reversible.

Model 479L & R: capped, left or right, factory installed.

Model 479-3: includes kick plate for 3' door, no cap, reversible.

Model 479-3L & R: includes kick plate for 3' door, capped, left or right, factory installed.

Model 479-4: includes kick plate for 4' door, no cap, reversible.

Model 479-4L & R: includes kick plate for 4' door, capped, left or right, factory installed.

Model 479B: 24" bolt protector.

SPECIFICATION

Panic Bolt Protectors shall be Series 479 as manufactured by JSM, Rancho Dominguez, CA.

GUARANTEE

479 series Panic Bolt Protectors are guaranteed for five years from shipping date against defects in materials and workmanship.

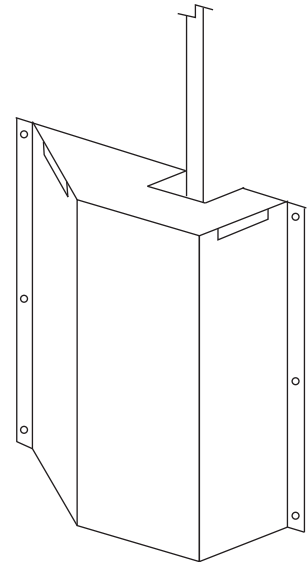

Model 479L

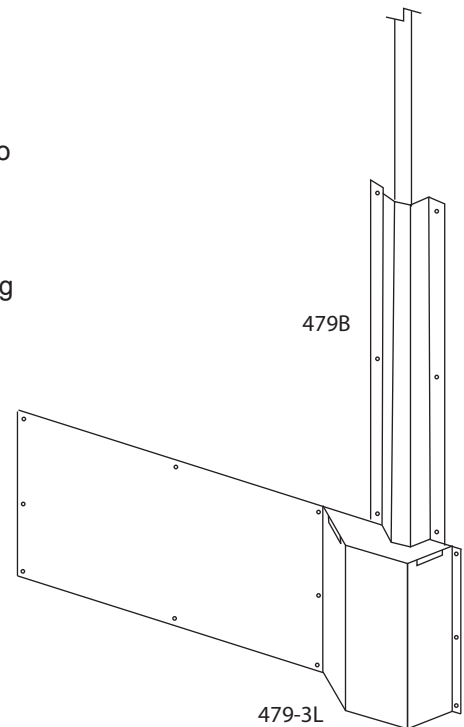

479B

479-3L